

# **Electrochemical Cells**

**Electrochemical cell      Galvanic cell**

**Voltaic cell**

**a device in which electricity is produced by a spontaneous redox reaction**

**by separating the oxidizing agent from the reducing agent electrons are transferred via an external conducting medium**

# Construct a galvanic cell based on the oxidation-reduction reaction



goal is to generate an electrical current

**Zn**

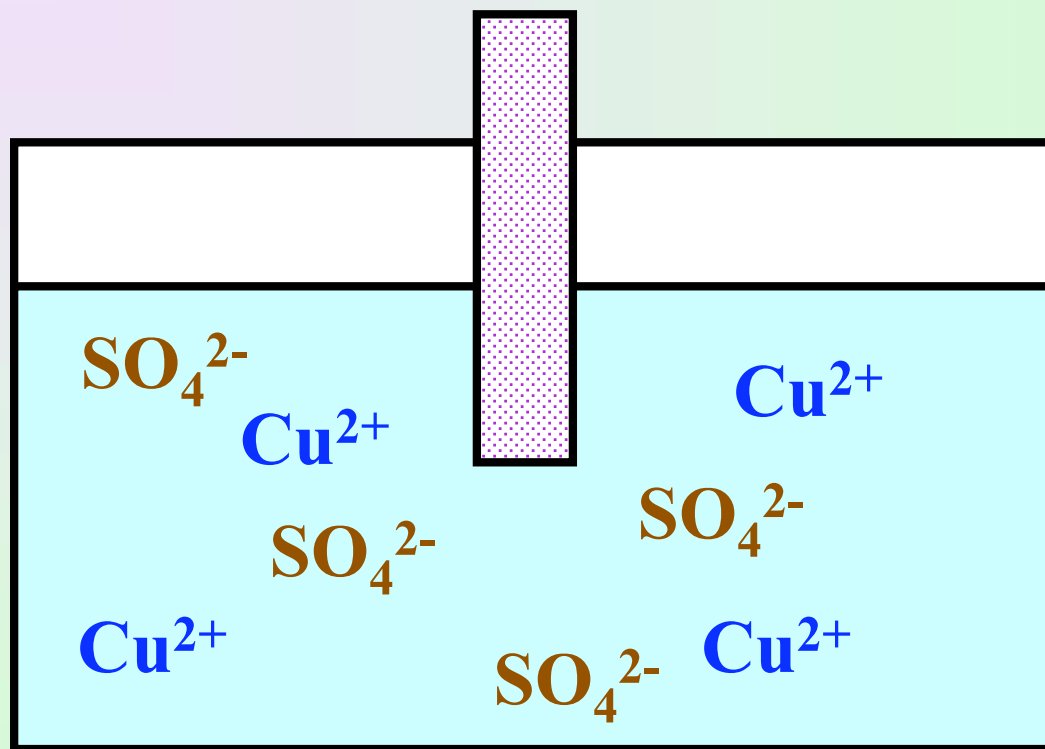

**electrons flow but no useful current is generated**

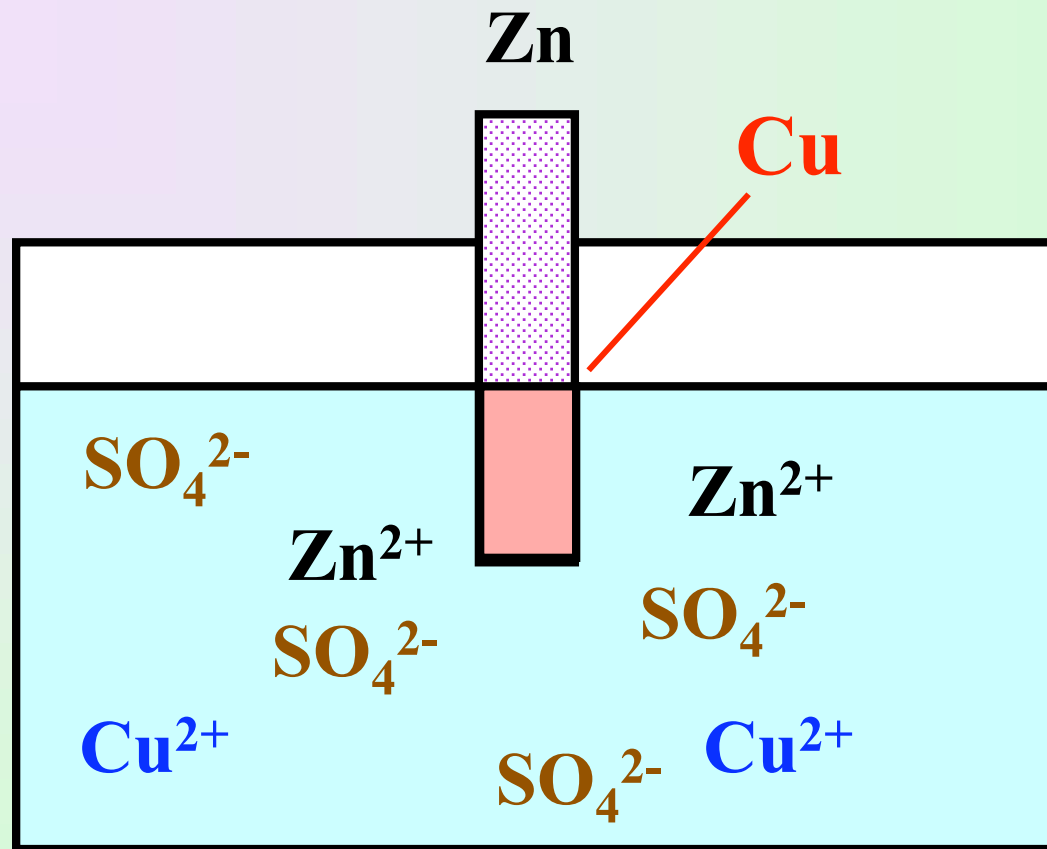

Consider the same two species in separate vessels

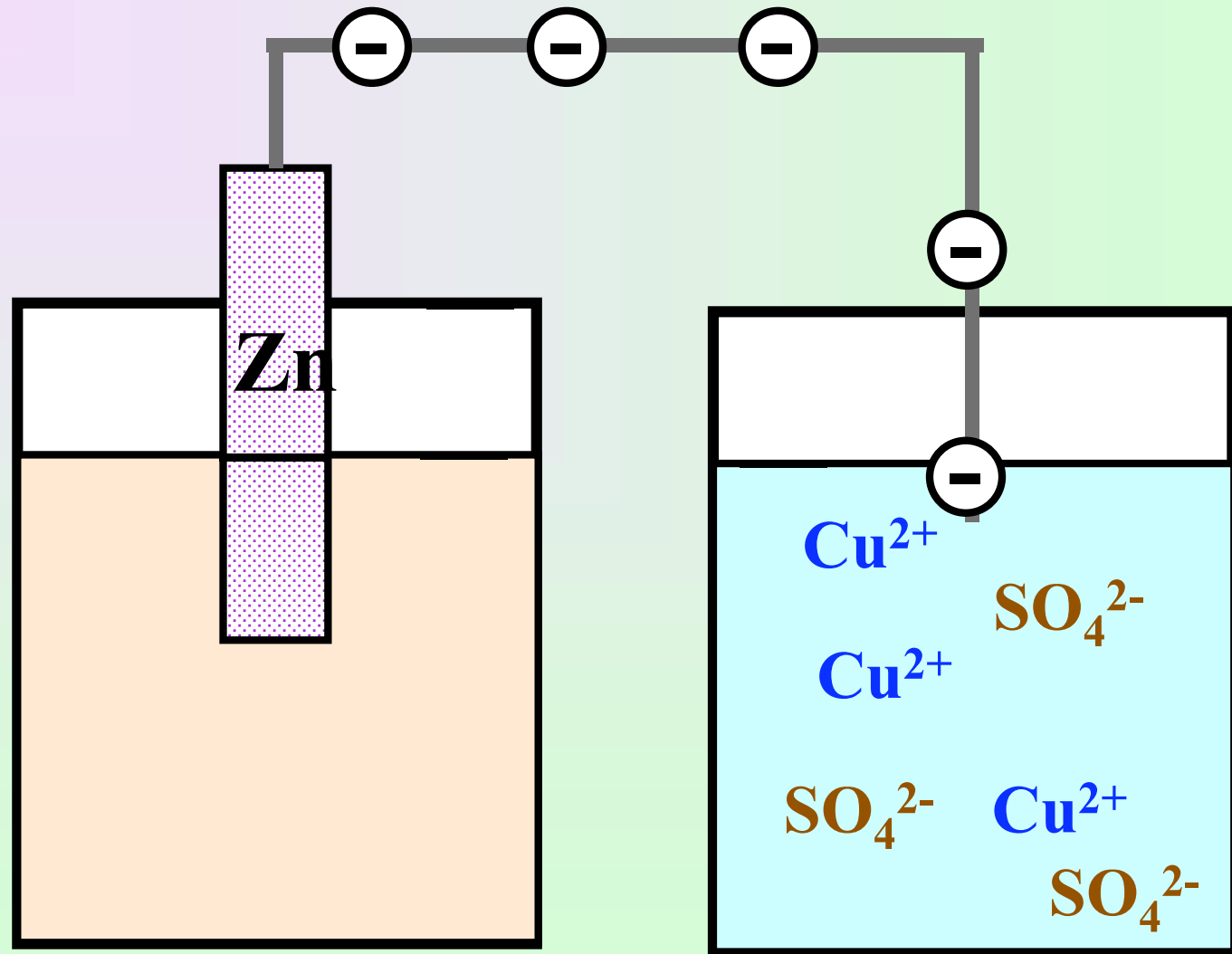

Consider the same two species in separate vessels

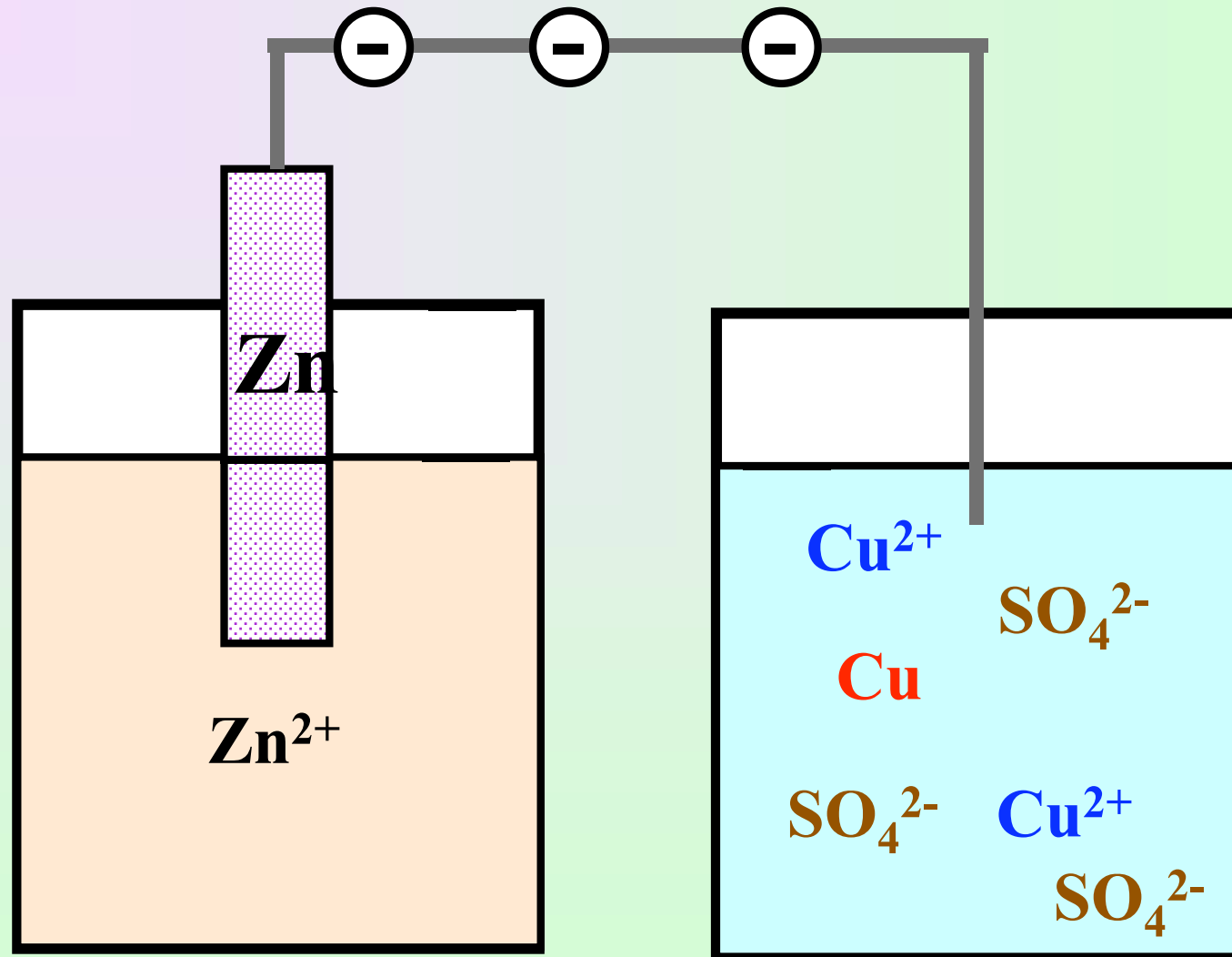

Consider the same two species in separate vessels  
electrons soon stop flowing

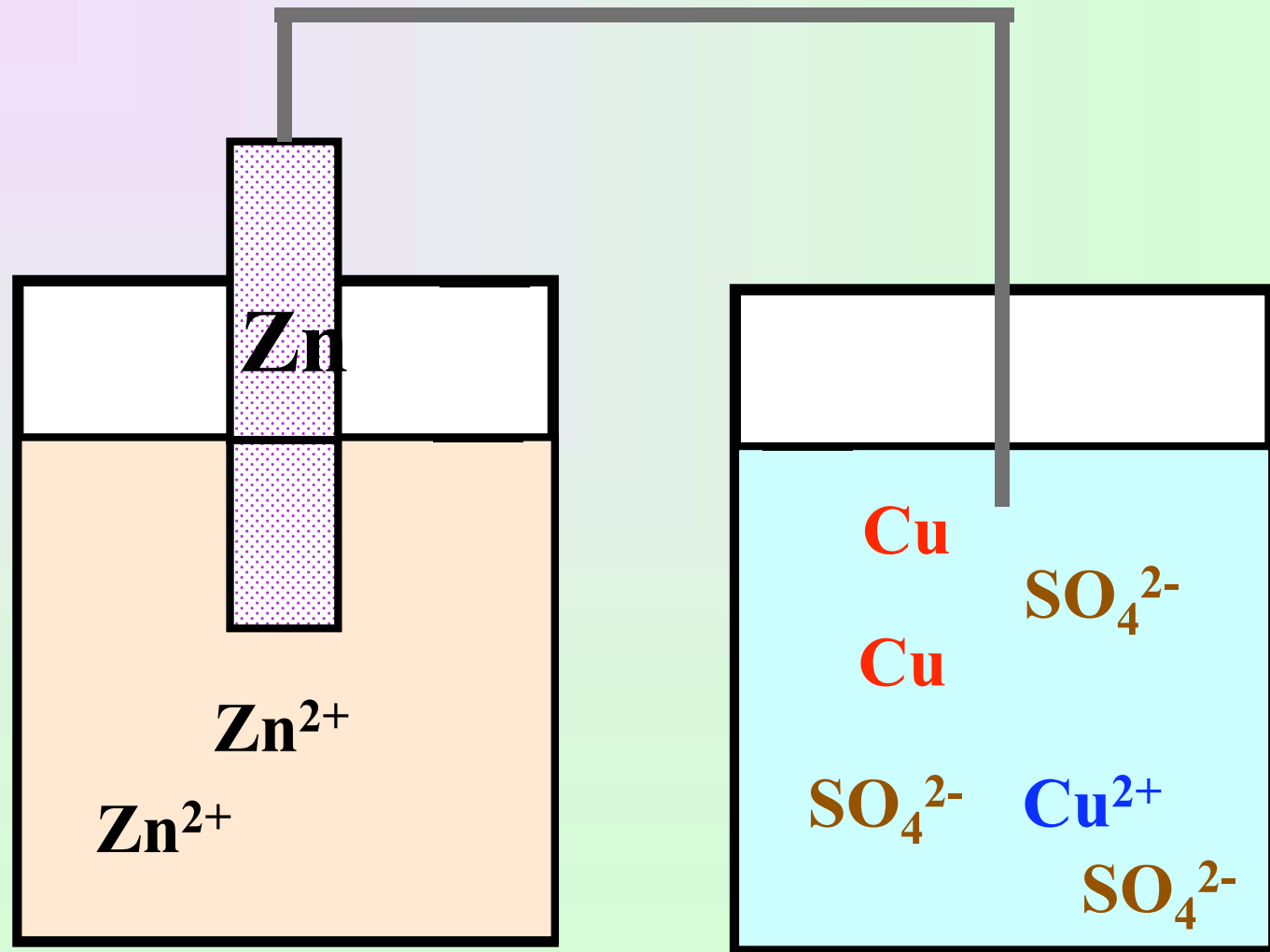

Connect the vessels by a salt bridge

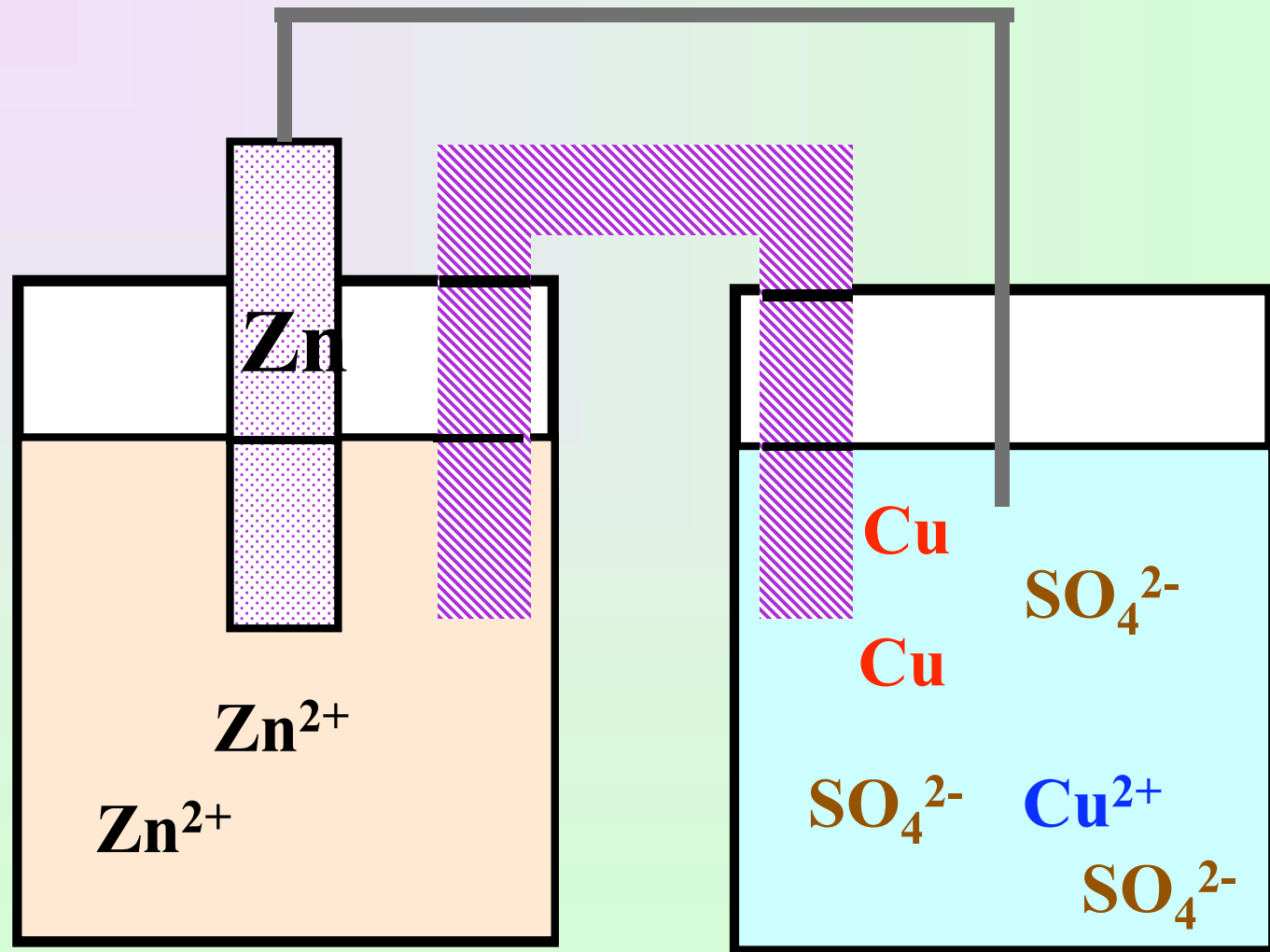

or a porous disk

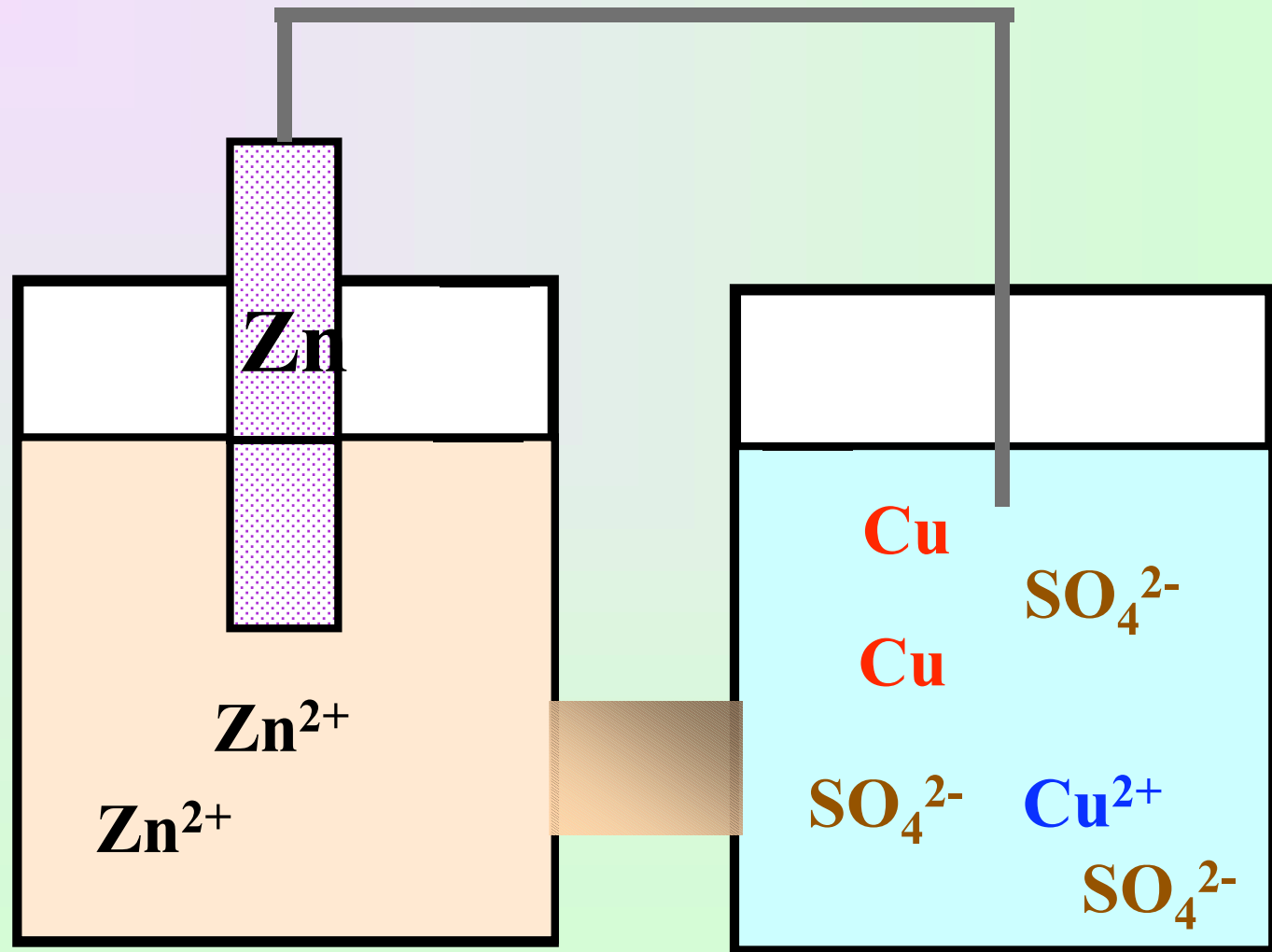

## a salt bridge

**completes the electric circuit**

**composed of an inert electrolyte (KCl,  $\text{NH}_4\text{NO}_3$ ) whose ions will not react with the other ions or electrodes in the cell**

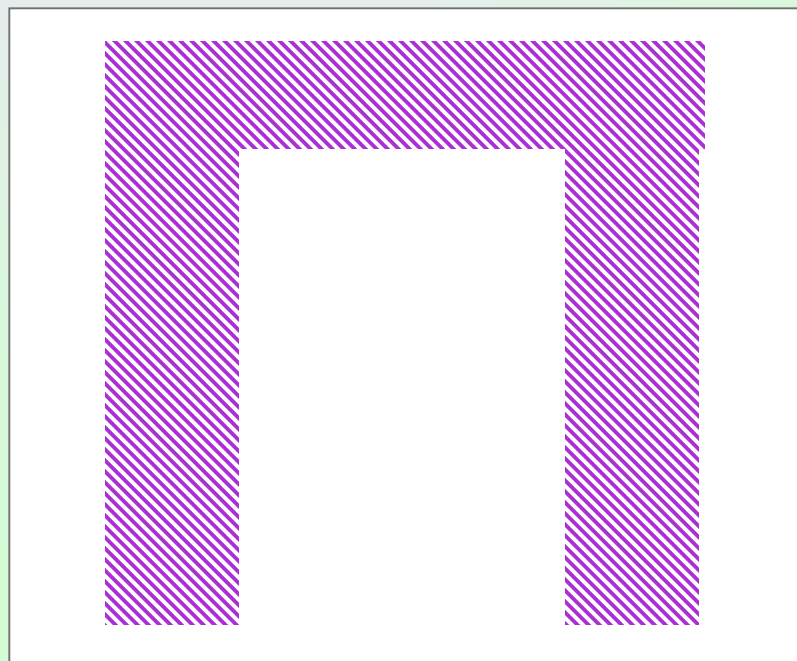

## a salt bridge

completes the electric circuit

composed of an inert electrolyte (**KCl**,  $\text{NH}_4\text{NO}_3$ ) whose ions will not react with the other ions or electrodes in the cell

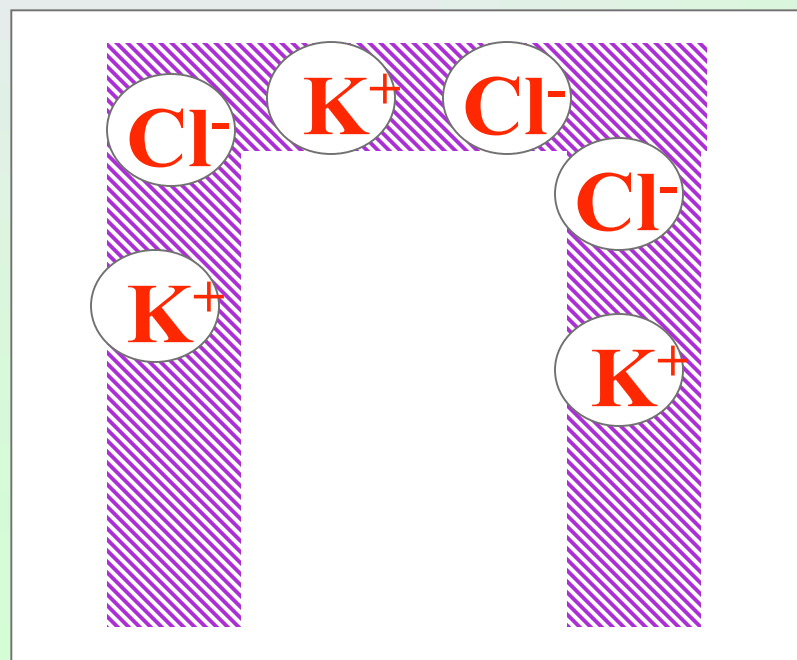

# a salt bridge

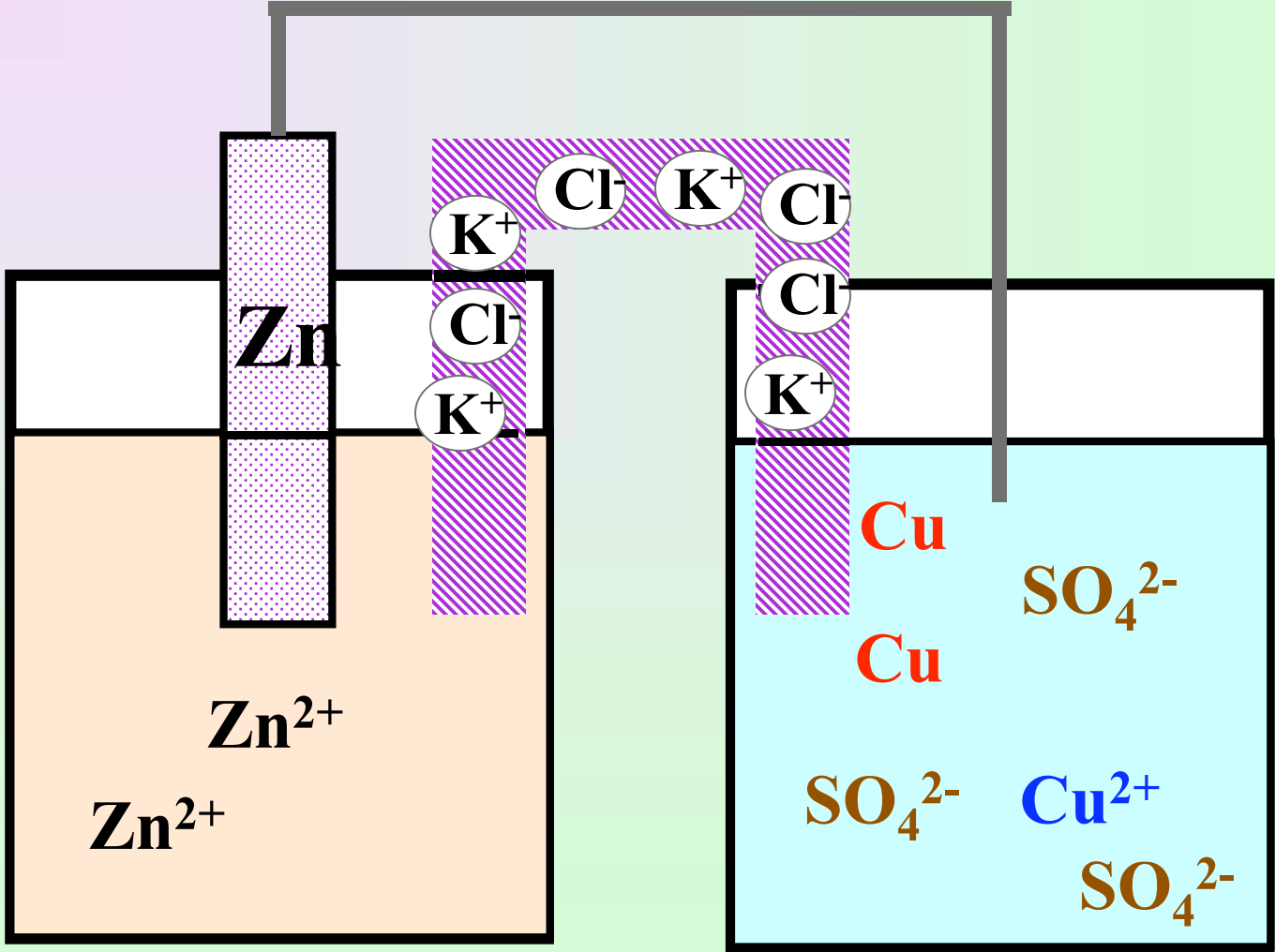

# Ion flow balances charges

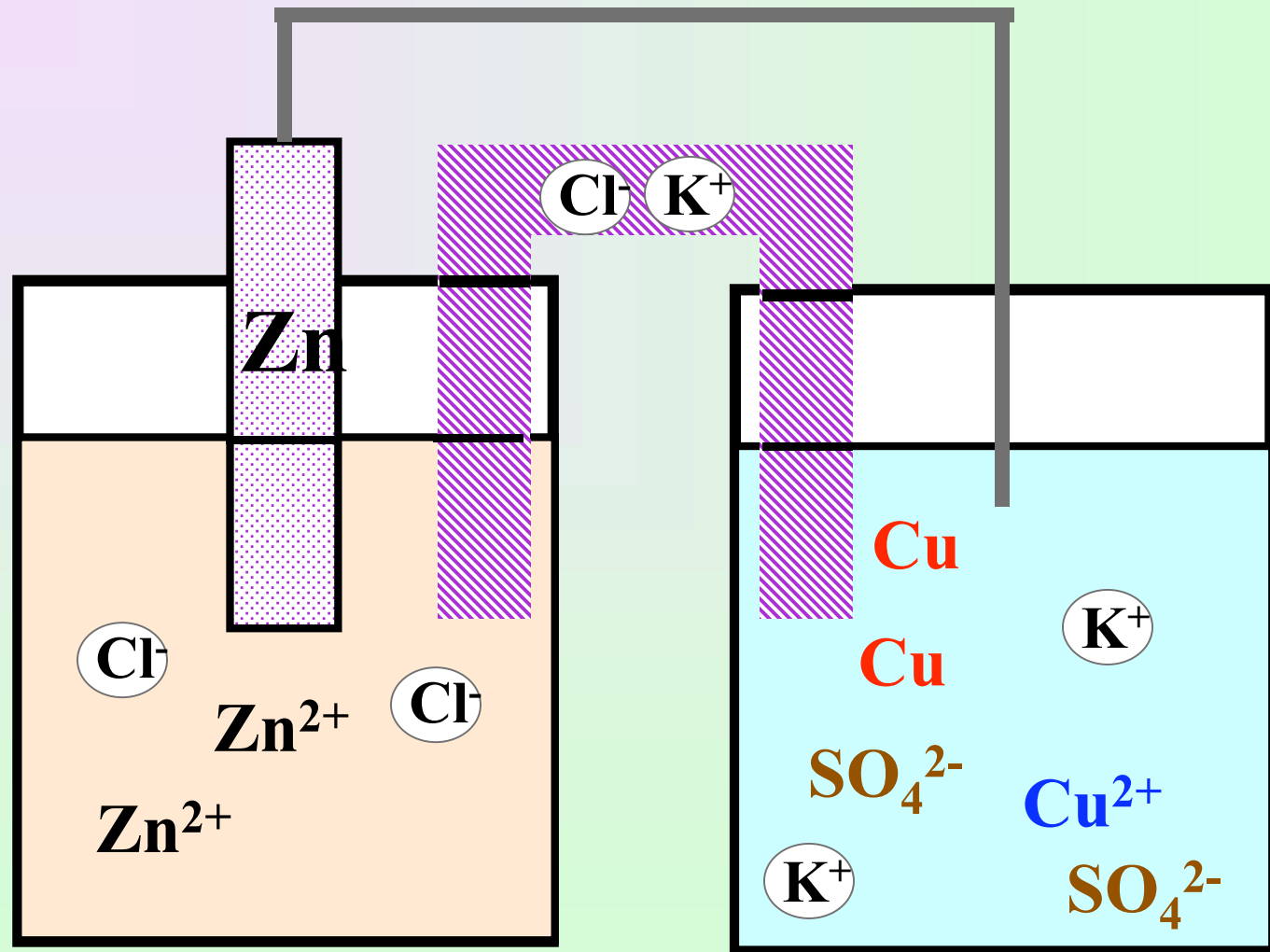

# Ion flow balances charges and permits electron flow

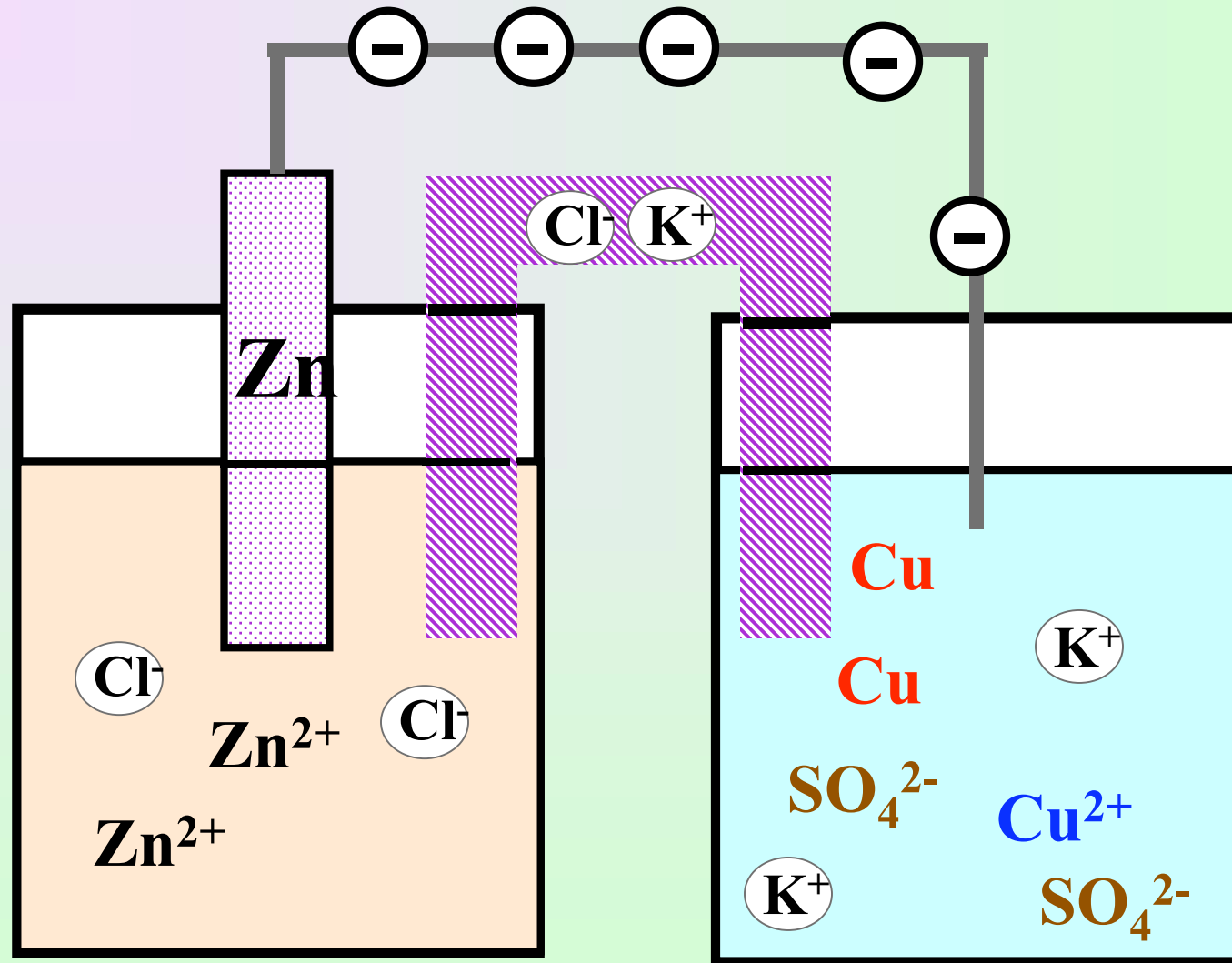

# Galvanic cell

**Anode**

where  
oxidation  
occurs

**Cathode**

where  
reduction  
occurs

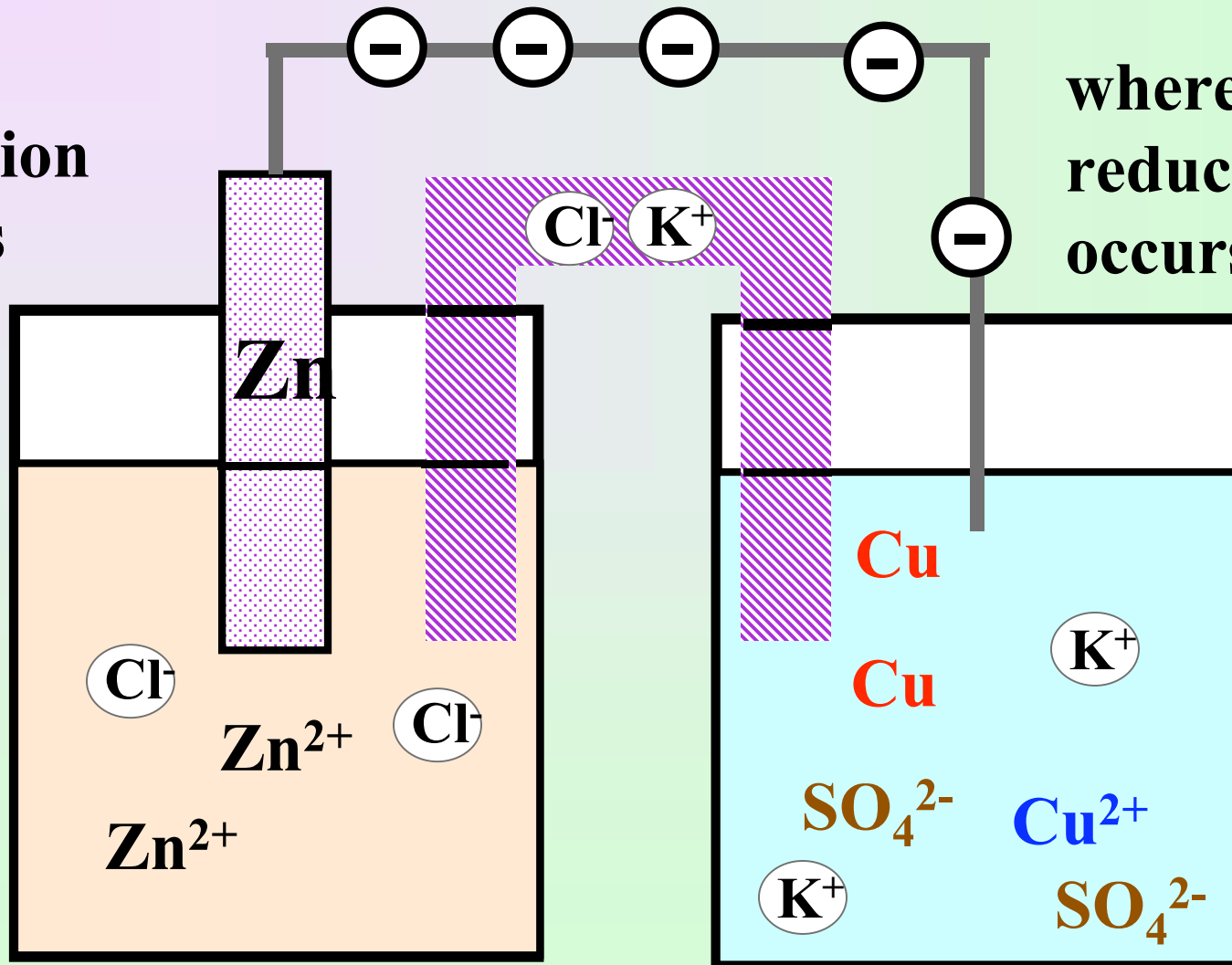

# Cell diagram

**Anode**

**Cathode**



**salt bridge**

**phase boundary**

**phase boundary**

*By convention the anode is written first ,the other components appear as you would encounter them moving to the cathode.*

# *Cell potential*

---

**also called electromotive force (emf)**

**results from difference in energy of an electron at the two electrodes**

**symbol is script E ( $\mathcal{E}_{\text{cell}}$ )**

**unit is volt (V)**

**1 V = 1 joule/coulomb**

**Cell potential = 1.10 V**

**Recall  
the  
galvanic  
cell**

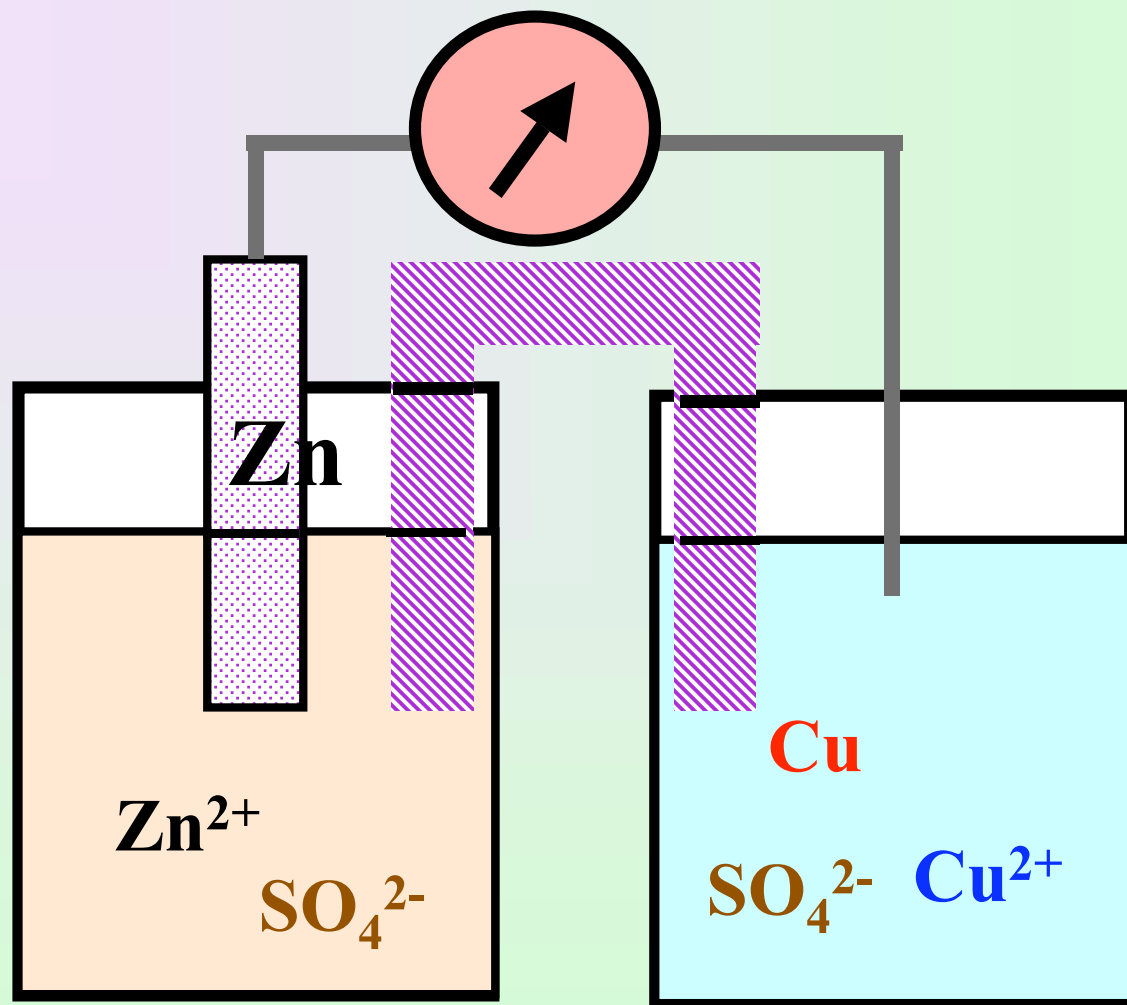

**when all species are in their standard state**