

Updating the Atomic Theory

On the basis of Dalton's Atomic Theory:

An atom is the basic unit of an element that can enter into chemical combination.

Three major differences between modern atomic theory and Dalton's atomic theory

1. Atoms are **NOT** indivisible. They are made up of smaller particles: electrons, protons and neutrons.
2. Atoms **CAN** be changed from one element to another, but **NOT** by chemical reactions.
3. Atoms of the same element are **NOT** exactly alike. They can have different masses.

Interactions Between Electric Charges

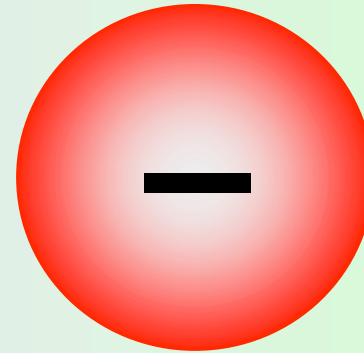
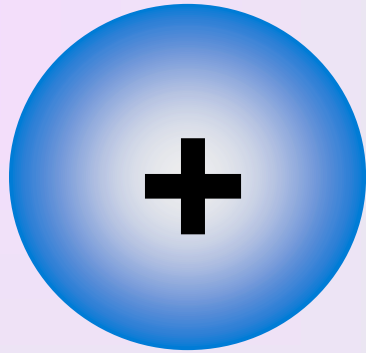

positive and negative charges

- **objects with an equal amount of positive and negative charge are said to be electrically neutral**

Forces between charges

Electrostatic Force

- objects with like charge repel

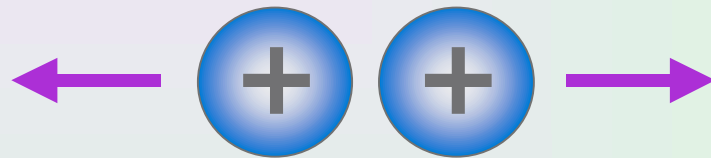

Forces between charges

Electrostatic Force

- objects with like charge repel



- objects with opposite charge attract

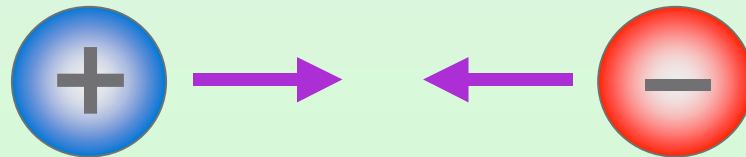

Forces between charges

Electrostatic Force

- objects with like charge repel



- objects with opposite charge attract

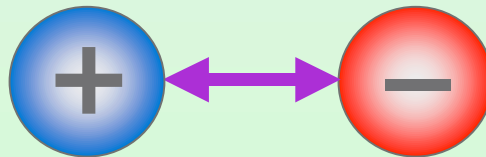

Forces between charges (cont...)

- **electrostatic force becomes greater the more excess charge**
- **electrostatic force becomes smaller the greater the distance separating the charges**

Searching for Atomic Structure

The Electron

The charge-to-mass ratio of an electron was determined by physicist **J.J. Thomson** in a series of experiments done between 1908 and 1917.

charge-to-mass ratio = -1.76×10^8 coulomb/g

Cathode Ray Tube

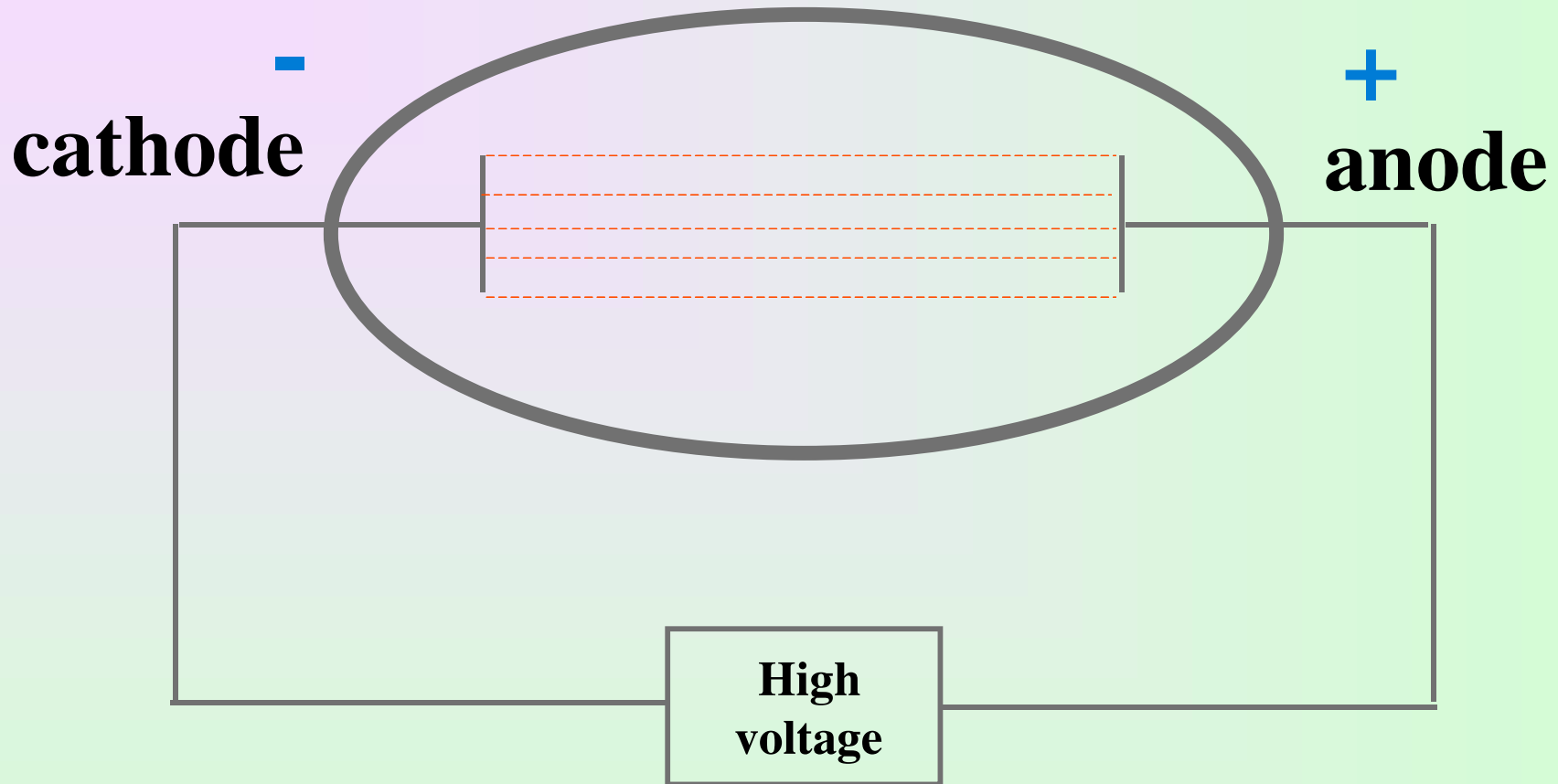

When high voltage is applied to the electrodes a glow was noticed between them.

Cathode Ray Tube

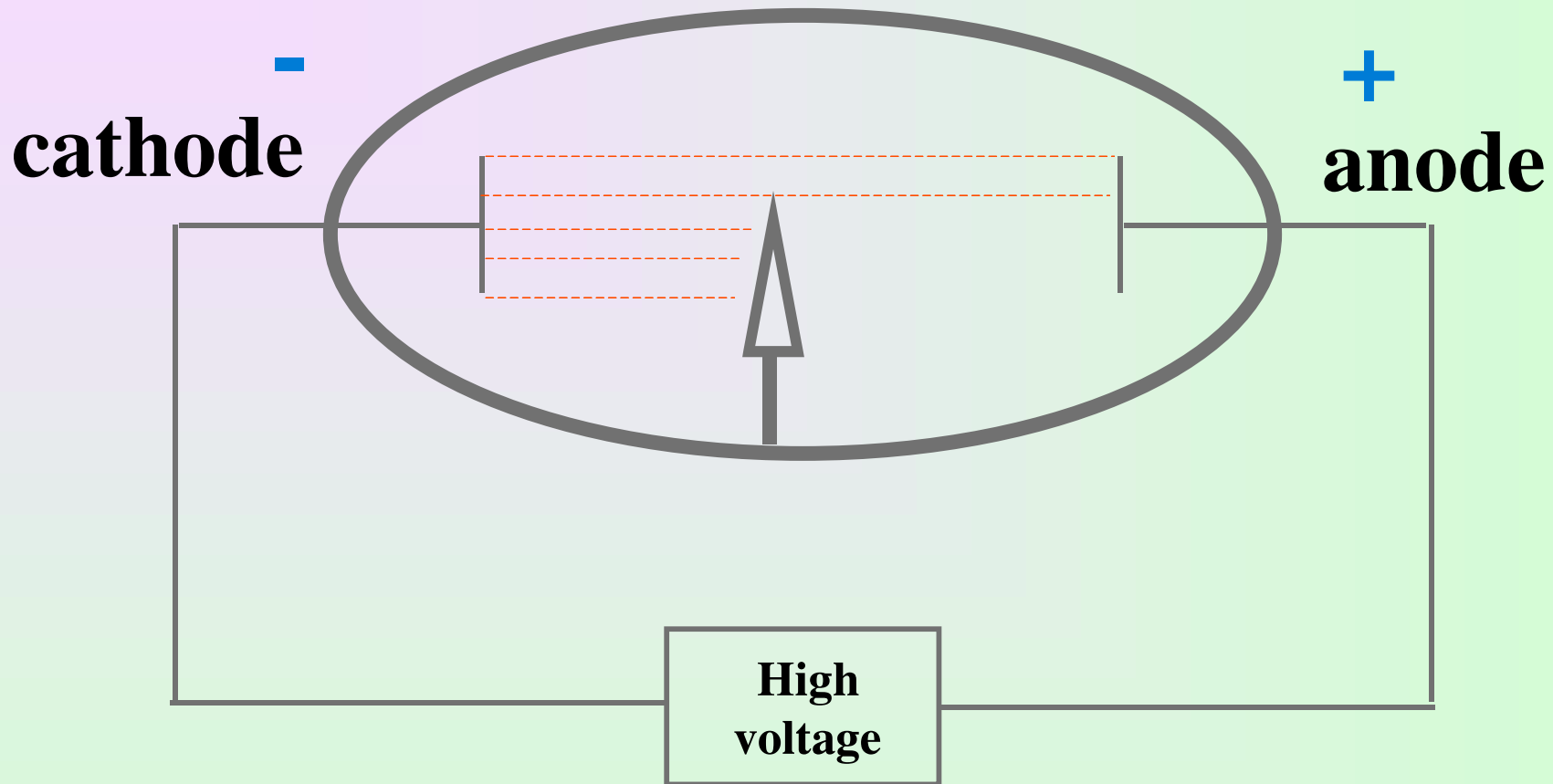

When an object was placed in the path of the glow, it blocked part of the beam showing that the beam originated at the negative electrode.

Cathode Ray Tube

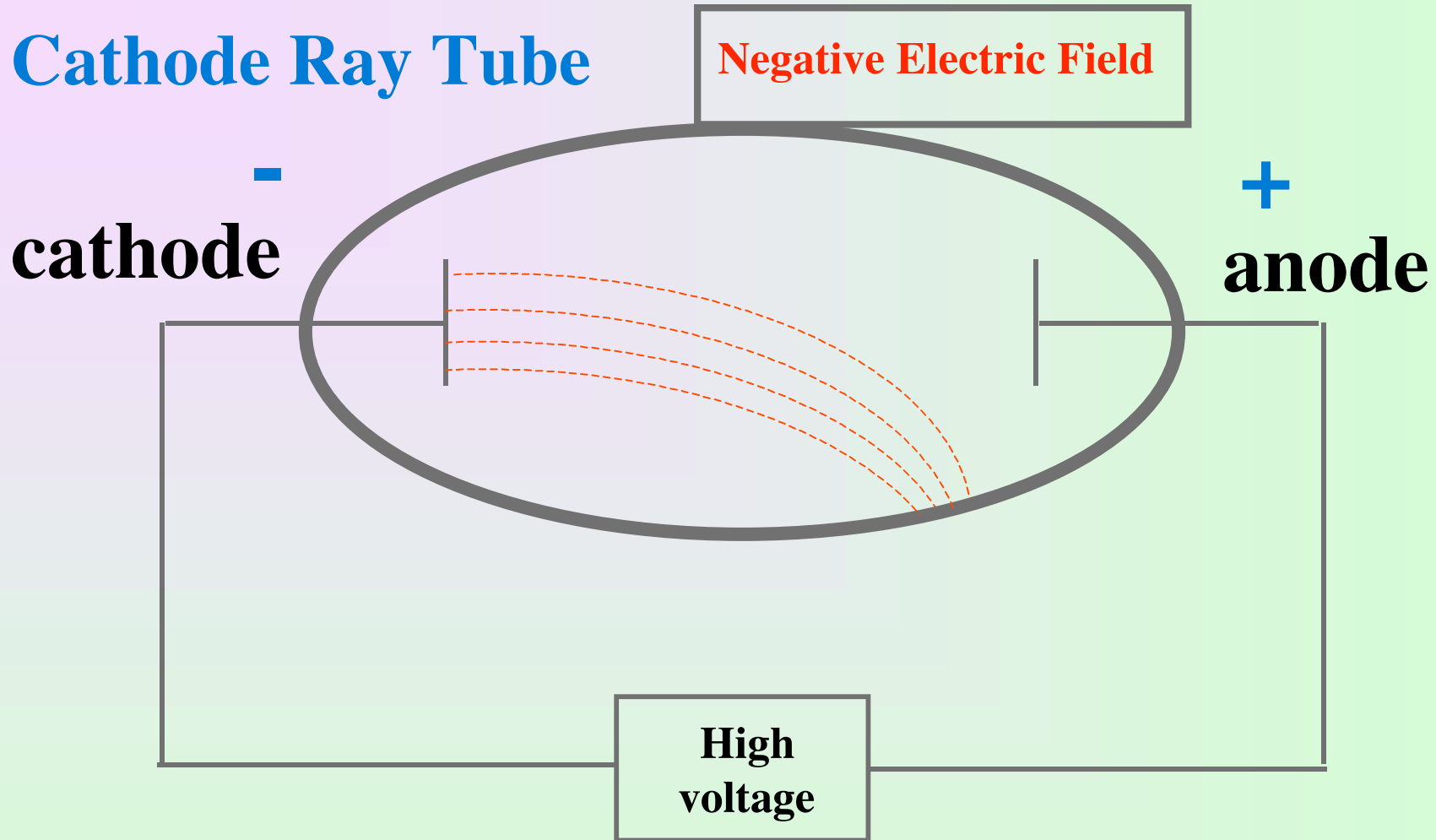

The fact that the rays were repelled by the negative electric field indicated that they had a negative charge with an e/m ratio of -1.76×10^8

J.J. Thomson's plum pudding model

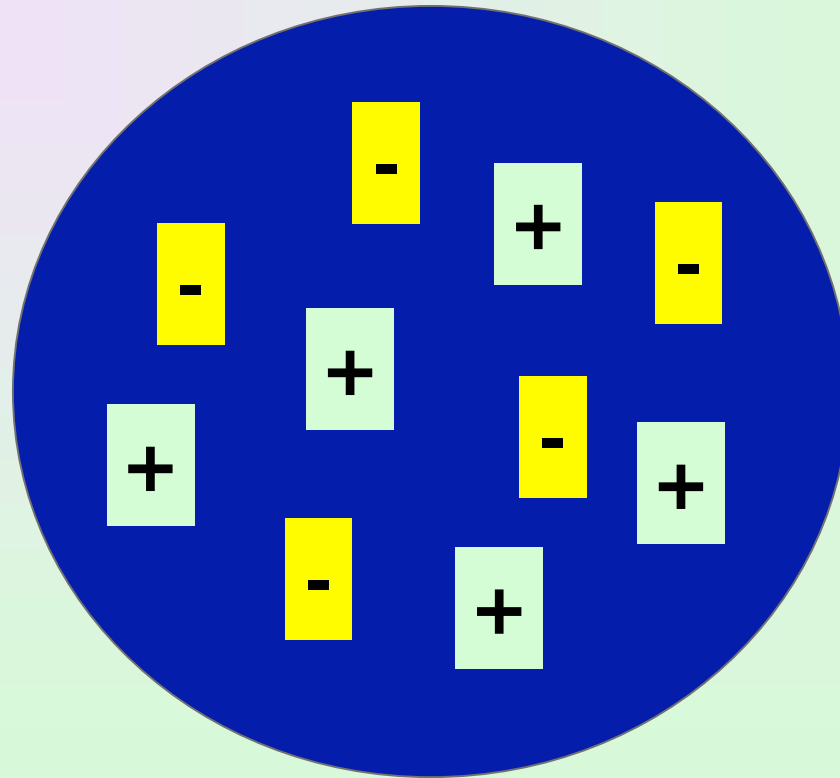

The Electron

R.A. Millikan measured the charge of an electron to be -1.60×10^{-19} coulomb

Since the charge-to-mass ratio is -1.76×10^8 coulomb/g, the mass of an electron must be 9.11×10^{-31} kg.

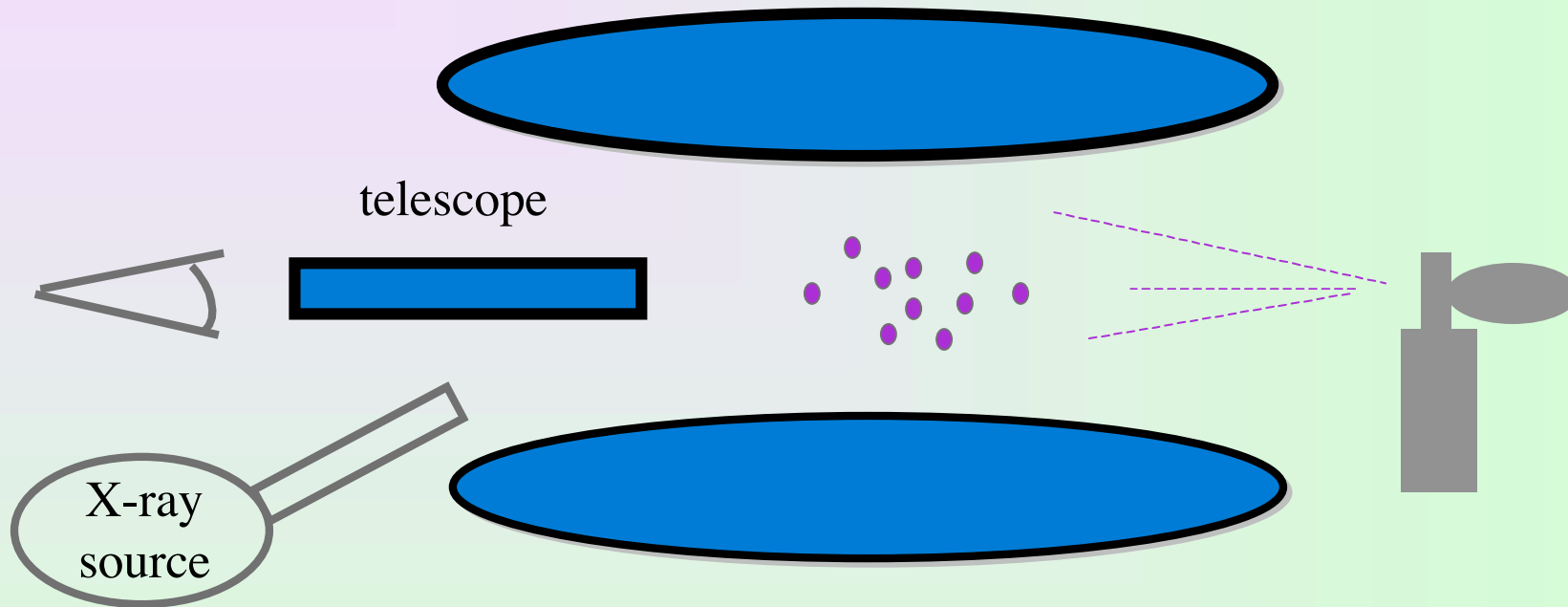

Oil droplets settle into a beam of X rays causing them to become charged with electrons.

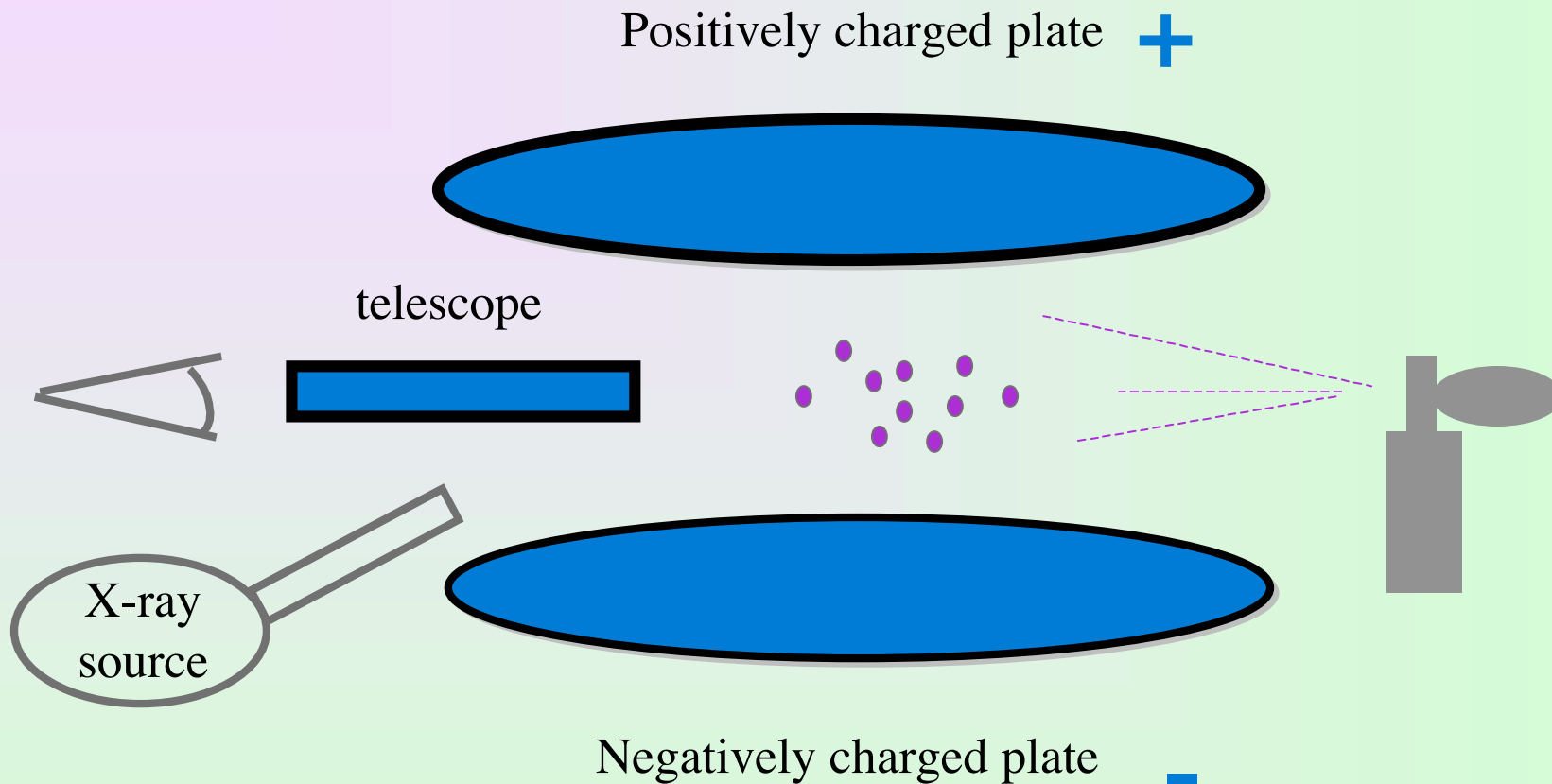

A positive plate attracts the “negative oil droplets” the negative plate repels them making the droplets stand still

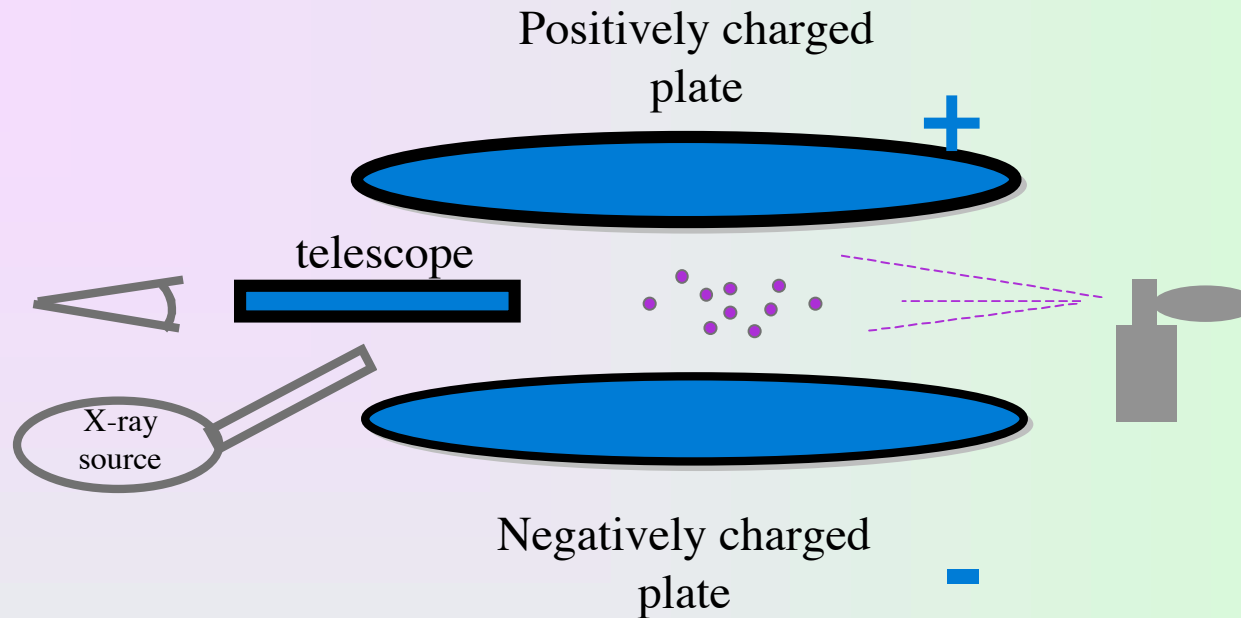

Knowing the density of the oil, Millikan could calculate the mass, m , of each oil droplet (**volume x density = mass**)

the force of gravitational attraction was **$Force = m G$**

the force of electrical force was **$Force = E e$**

E is the applied voltage, e is the charge of the electron

$$m_{\text{droplet}} G = E e$$

$$e = -1.6 \times 10^{-19} \text{coulomb}$$

**It was found that certain elements
spontaneously emit radiation**

Radioactivity

Radioactive substances emit three kinds of particles and/or radiation(light):

□ particles (helium nuclei)

□ particles (electrons)

□ rays

The Nucleus

Ernest Rutherford (gold foil experiment) deduced the nuclear model of the atom, with an extremely small, dense and positively charged nucleus surrounded by empty space sparsely occupied by electrons.

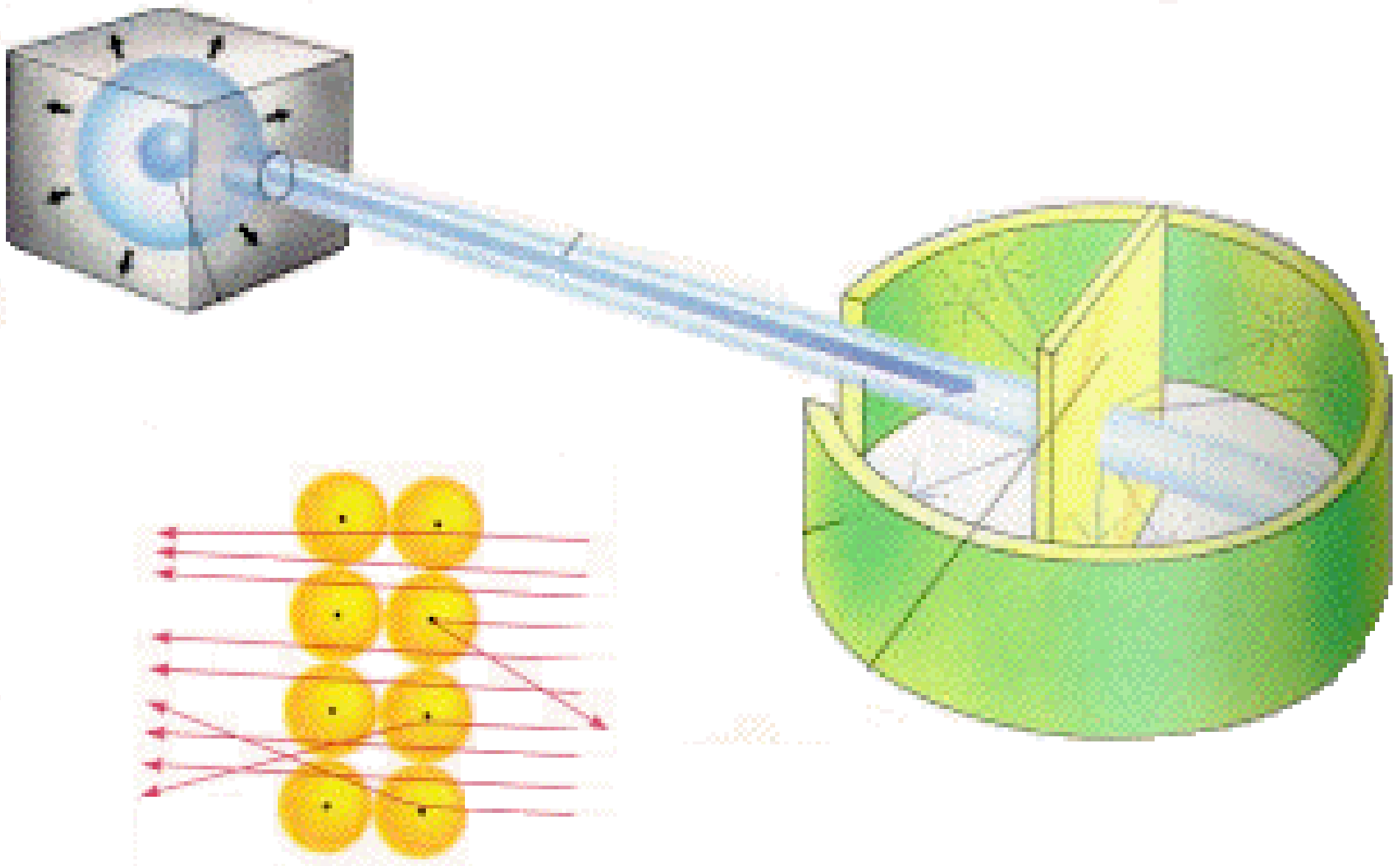

Positive alpha particles(helium nuclei)
deflected by positive gold nuclei

The Proton

Ernest Rutherford discovered that the positive charge was not spread out over the entire volume of the atom but was concentrated in the nucleus.

The positively charged particles in the nucleus are called protons. They have the same charge as an electron but have almost 2,000 times more mass.

Rutherford's Atomic Model left one major problem

It was known that the hydrogen atom contained one proton and that the helium atom contained two protons. So the mass ratio should have been 2:1.

In reality the ratio is 4:1.

There must be another particle...

The Neutron

Was discovered by **James Chadwick** in 1932. It is neutral (uncharged) and has slightly greater mass than a proton.

Mystery solved.

Shortcomings of Rutherford's Model

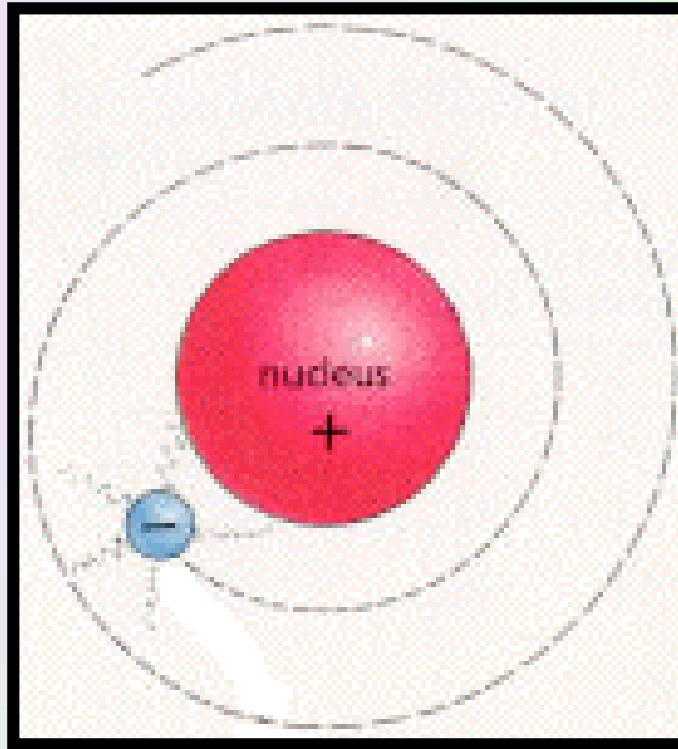

Classical physics states that a charged particle traveling in a curved path radiates energy.

Electrons would continually give off energy, slow down and spiral in towards the nucleus.

The properties of atoms and molecules are not governed by the same physical laws as larger objects.

Quantum Mechanics:

the physics of the very small

To be continued

The Modern View of Atomic Structure

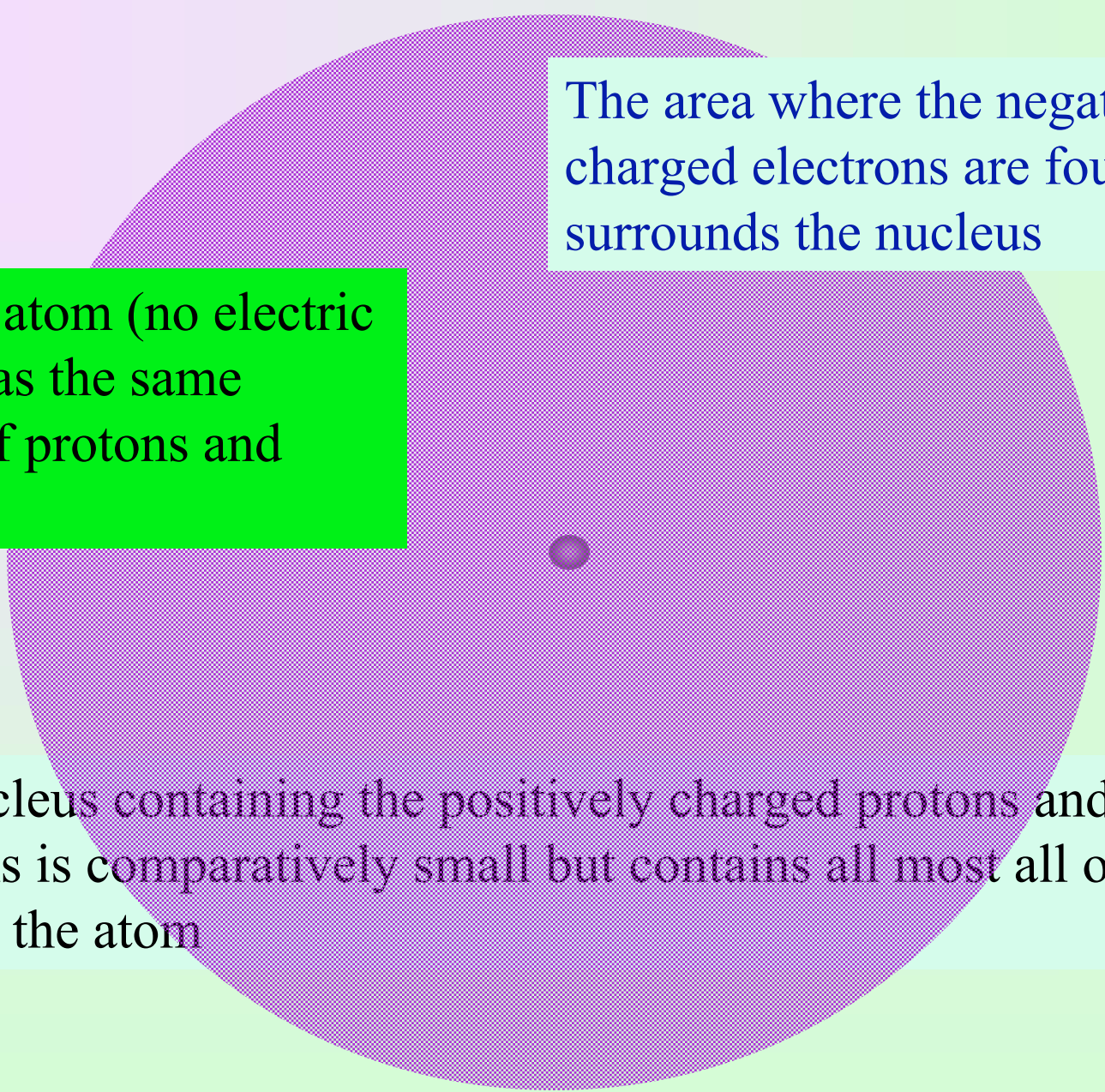
A diagram of an atom. At the center is a small, dark purple sphere representing the nucleus. Surrounding it is a large, light purple, semi-transparent sphere representing the electron cloud. The background is a gradient from light purple on the left to light green on the right.

The area where the negatively charged electrons are found surrounds the nucleus

A neutral atom (no electric charge) has the same number of protons and electrons.

The nucleus containing the positively charged protons and neutral neutrons is comparatively small but contains almost all of the mass in the atom

Atoms are composed of

PROTONS

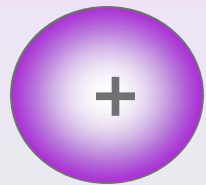

positively charged

mass = 1.6726×10^{-27} kg

NEUTRONS

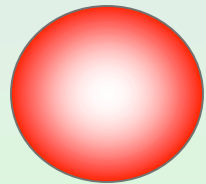

neutral

mass = 1.6750×10^{-27} kg

ELECTRONS



negatively charged

mass = 9.1096×10^{-31} kg

PROTONS

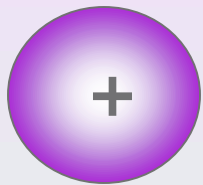

positively charged

NEUTRONS

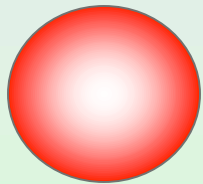

neutral

ELECTRONS



negatively charged

mass = 9.1096×10^{-31} kg

Nucleons

General term for a particle found in the nucleus